

IDEAL LOGIC+ 30 BOILER EXTERNAL

MANUFACTURED BY:

ideal
HEATING

The Logic+ 30 **Condensing** System Boiler provides excellent energy saving, with ultra quiet operation.

- Made in the UK
- Custom designed external case
- 1:5 Modulation rate
- Built in Frost Protection
- Large backlit LCD display
- Aluminium Silicon Heat Exchanger
- Light weight and compact design
- Quiet operation
- User friendly control panel

HUNT
HEATING®

10 YEAR*
WARRANTY

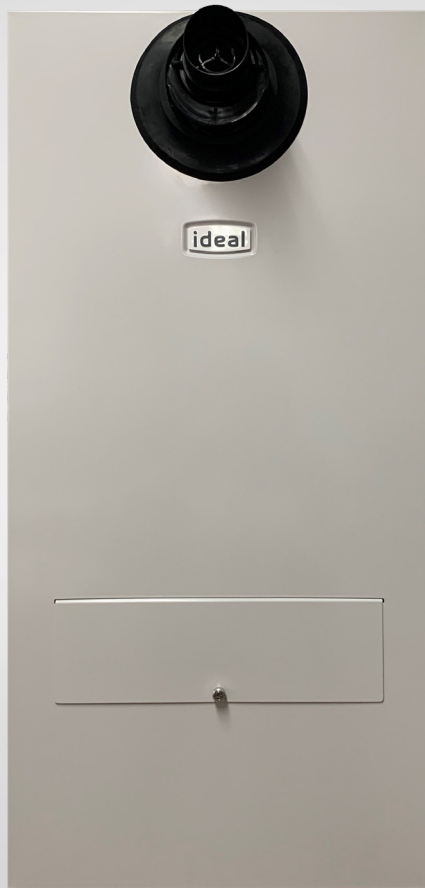

MODELS

Logic+ 30kW System

MEASUREMENTS

902 (H) x 425 (W) x 312 (D) mm

MAGNACLEAN FILTER



WATER TREATMENT



SHOWROOM

11 Fiveways Boulevard
Keysborough
VIC 3173

PHONE 1300 00 1800

FAX (+613) 9798 5133

enquiries@huntheat.com.au

HUNT HEATING
The smart choice.

www.huntheat.com.au

General Data		30 System	
Gas Supply - NG / LPG		1.13kPa / 2.75kPa	
Gas Supply Connection		1/2"	
Flow Connection		3/4"	
Return Connection		3/4"	
Flue Terminal Diameter		mm 100	
CO2 Content (± 0.7) NG/LPG	Max. CH	8.9%/10.7%	
	Min. CH	8.7%/10.4%	
Maximum Working Pressure (Sealed Systems)		kPa 250	
Electrical Supply		230 V ~ 50 Hz	
Power Consumption		W 100	
Min. thermostat cable size		1mm twin active	
Water Content		Litre 1.2	
Height		mm 902	
Width		mm 425	
Depth		mm 312	
Packaged Weight		kg 46.8	
Installation Weight		kg 43.2	
Performance Data		Min	Max
Boiler output - Mean 70°C		kW 6.1	30.3
Boiler output - Mean 40°C		kW 6.4	31.0
Gas Consumption		MJ/h 23.01	119.41
Boiler Efficiency		% 91.1	

CLEARANCES

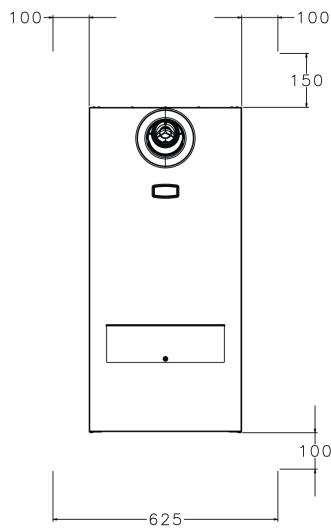

BOILER DIMENSIONS

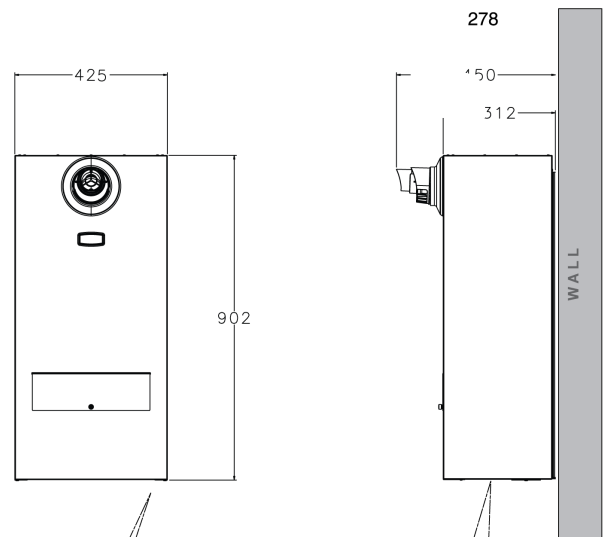

Water Connections and Gas Connection

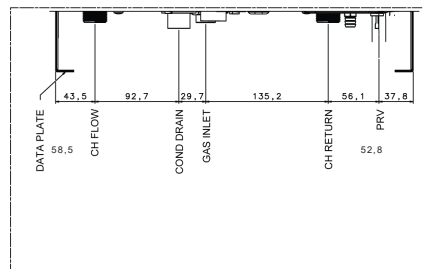

Underside View - Pipe Dimensions to Wall

